

Meyra Sprint PC control board #1 from 6.7.2006

The drawing is seen from top  
 Width of grid is 2.54 mm  
 Wires on top of board are drawn in red/orange  
 GND is drawn blue  
 +5V is drawn magenta  
 Use thick wire for thicker lines

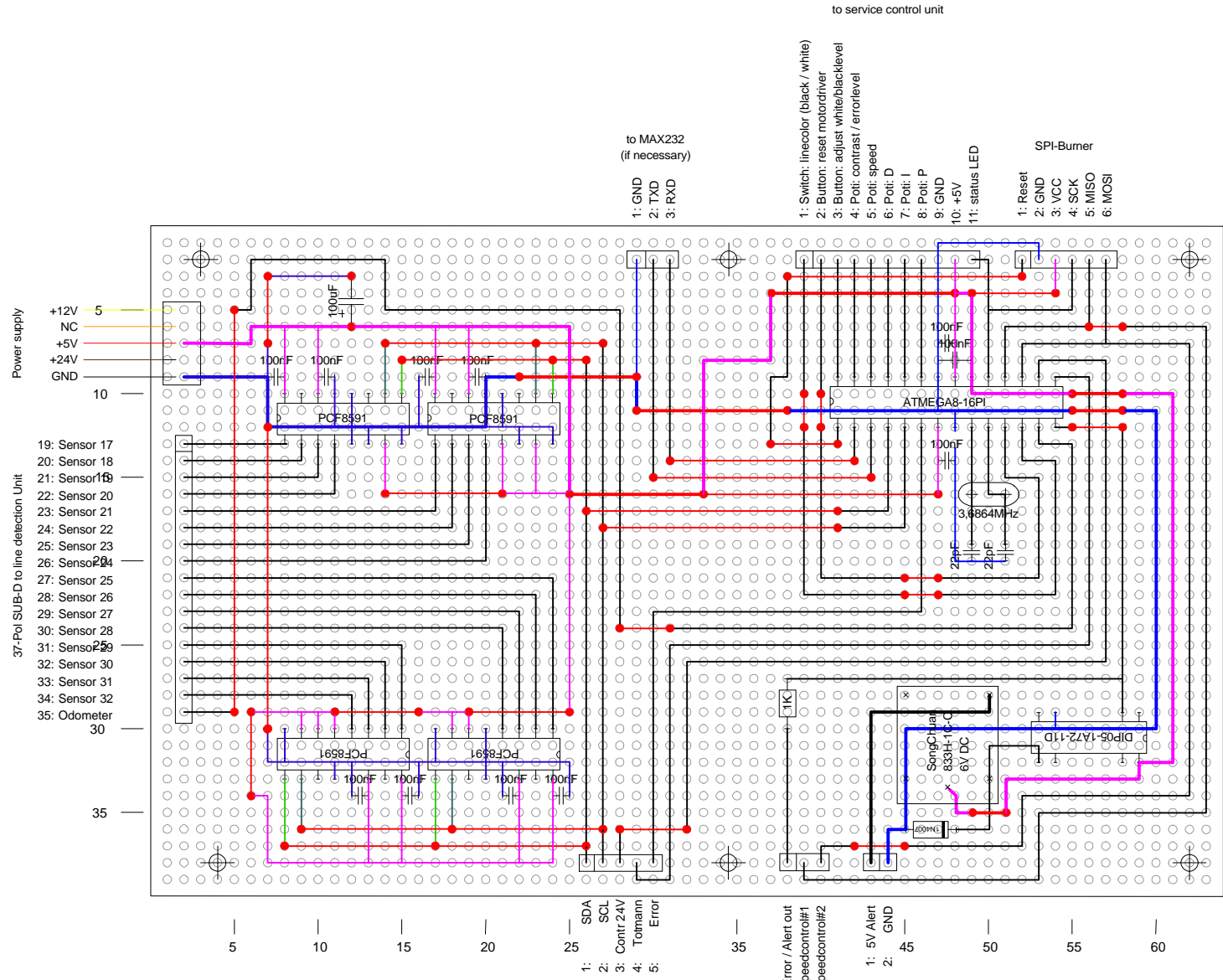

Meyra Sprint PC control board #2 from 6.7.2006

The drawing is seen from top  
 Width of grid is 2.54 mm  
 Wires on top of board are drawn in red/orange  
 GND is drawn blue  
 +5V is drawn magenta  
 Use thick wire for thicker lines

from board 1 /  
to controller

to / from board 3  
maincontrol

to blue light /  
buzzer

to service control unit

to MAX232  
(if necessary)

- 1: GND
- 2: TXD
- 3: RXD

- 1: Switch: linecolor (black / white)
- 2: Button: reset motor driver
- 3: Button: adjust white/black level
- 4: Pot: contrast / error level
- 5: Pot: speed
- 6: Pot: D
- 7: Pot: I
- 8: Pot: P
- 9: GND
- 10: +5V
- 11: status LED

SPI-Burner

- 1: Reset
- 2: GND
- 3: VCC
- 4: SCK
- 5: MISO
- 6: MOSI

- 1: SDA
- 2: SCL
- 3: Contr 24V
- 4: Tommann
- 5: Error

- 1: Error / Alert out
- 2: Speedcontrol#1
- 3: Speedcontrol#2

- 1: 5V/Alert
- 2: GND